

PRESS MASTER

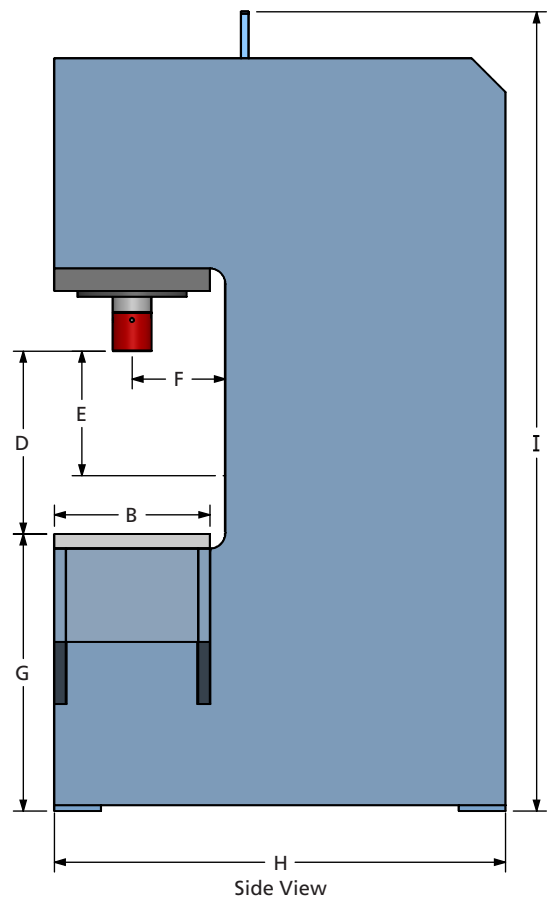

MODEL NUMBER	KEY	SP-100	SP-150	SP-250
Tons of force (maximum)		100	150	250
Approach speed (inches per minute)		20	24	17
Press speed (inches per minute)		20	6	4
Return speed (inches per minute)		26	28	21
Table (left to right)	A	96	96	96
Table (front to back)	B	20	20	20
Daylight	D	27	26	24
Maximum stroke	E	18	16	16
Throat	F	12	12	12
Floor to table	G	35	35	36
Front to back	H	58	58	58
Height (overall)	I	103	103	103
Width	J	41	42	43
Motor HP @ 1750 RPM		10 HP	10 HP	10 HP
Voltages available		230 / 460 / 575 3 PH. 60 HZ.		

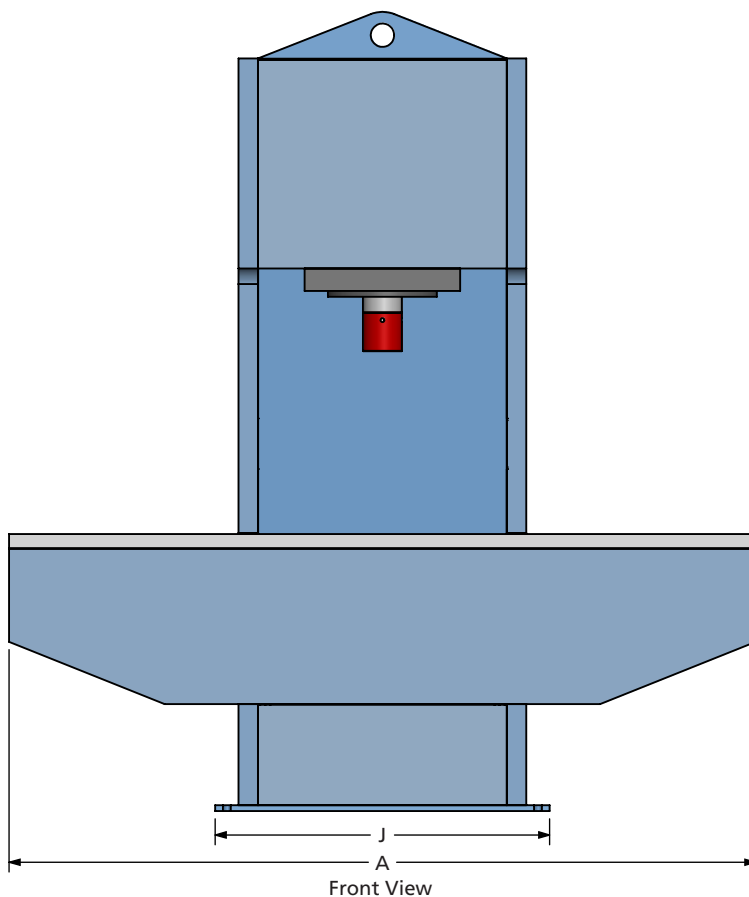

PRESS MASTER

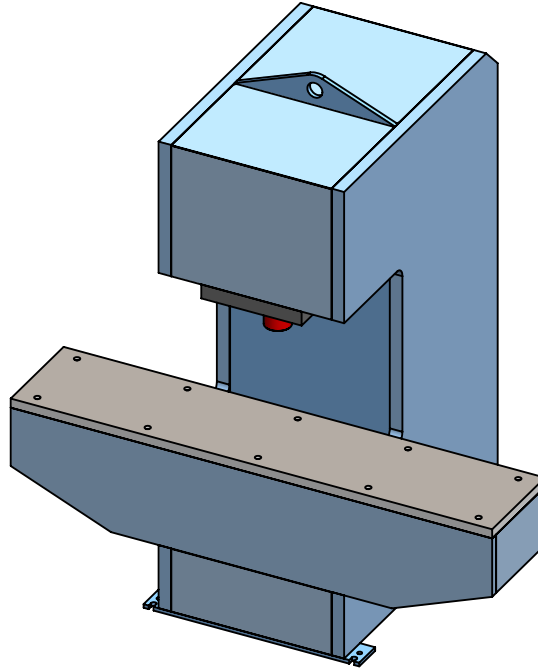

STRAIGHTENING PRESSES 100 / 150 / 250 TON

STANDARD FEATURES

- ✓ **Electric / Hydraulic operation** provides smooth, consistent pressing action.
- ✓ **Flat ram nose** can be easily changed to allow the user to adapt the press to a specific job.
- ✓ **Quality Baldor motor**, low speed.
- ✓ **Low speed pump** - quiet, dependable operation.
- ✓ **Pressure regulator** to limit the ram pressure.
- ✓ **Cylinder activation** is fingertip controlled, the more the hand lever is engaged the more the ram movement is accelerated. This allows the operator to control the proper speed for the task.
- ✓ **High capacity** 40 GAL. hydraulic oil reservoir.
- ✓ **Low pressure** hydraulic system maintains lower oil temperatures, resulting in higher efficiency and safer operation.
- ✓ **All hydraulic and mechanical parts are standard** in the industry, and available throughout North America.

AVAILABLE OPTIONS

Foot pedal-electric solenoid valve for hands-free operation, c/w electric control panel.

Adjustable stroke control c/w foot pedal-electric solenoid valve and electric control panel.

10 HP 230 VOLTS 1 PHASE 41 AMPS.

MODEL	WEIGHT (LBS.)	SHIPPING DIMENSIONS		
		L	W	H
SP-100	8,200	60"	96"	106"
SP-150	9,800	60"	96"	106"
SP-250	12,800	60"	96"	106"